

**STRATA PLAN OF LOT 2,
DISTRICT LOT 106, GROUP 2,
NEW WESTMINSTER DISTRICT,
PLAN BCP50757**

B.C.G.S. 92G.005

SCALE: 1:250

CIVIC: #4876 DELTA STREET, DELTA, B.C.

THE INTENDED PLOT SIZE OF THIS PLAN IS
432mm IN HEIGHT BY 280mm IN WIDTH
WHEN PLOTTED AT A SCALE OF 1:250 (B SIZE)

NOTES:

THIS PLAN LIES WITHIN INTEGRATED SURVEY AREA No.13, CITY OF DELTA, NAD83 (CSRS) 4.0.0.BC.1.MVRD.

GRID BEARINGS ARE DERIVED FROM OBSERVATIONS BETWEEN CONTROL MONUMENTS 84H0418 AND 84H0420 (NAD83(CSRS) 4.0.0.BC.1.MVRD).

THIS PLAN SHOWS HORIZONTAL GROUND LEVEL DISTANCES UNLESS OTHERWISE SPECIFIED. TO COMPUTE GRID DISTANCES, MULTIPLY GROUND LEVEL DISTANCES BY THE AVERAGE COMBINED FACTOR OF 0.999_ WHICH HAS BEEN DERIVED FROM GEODETIC CONTROL MONUMENTS _.

THE UTM COORDINATES AND ESTIMATED ABSOLUTE ACCURACY ACHIEVED ARE DERIVED FROM THE MASCOT PUBLISHED COORDINATES AND STANDARD DEVIATIONS FOR GEODETIC CONTROL MONUMENTS _.

AREAS ARE INTENTIONALLY REMOVED FROM THIS PLAN.

THE BUILDINGS SHOWN HEREON ARE WITHIN THE EXTERNAL BOUNDARIES OF THE LAND THAT IS THE SUBJECT OF THE STRATA PLAN.

THE BUILDINGS ON THIS STRATA PLAN HAVE BEEN PREVIOUSLY OCCUPIED.

LEGEND:

- S.L. DENOTES STRATA LOT
- (E) DENOTES ELECTRICAL
- (C) DENOTES COMMON PROPERTY - COMMON PROPERTY
- LCP DENOTES LIMITED COMMON PROPERTY (TYPICAL)

WATSON & BARNARD
B.C. LAND SURVEYORS
1524 56th STREET
DELTA, B.C., V4L 2A8
P: 604 943 9433

D.L. 106 GP. 2

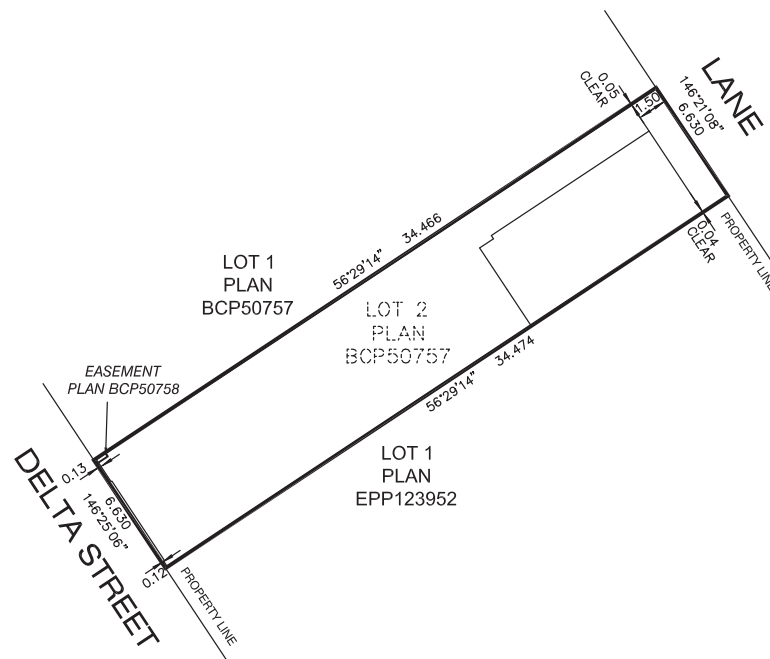

PRELIMINARY

THE FIELD SURVEY REPRESENTED BY THIS PLAN
WAS COMPLETED ON THE XX DAY OF XXXX, 2025
CONNOR R. EMBLETON, BCLS (982)

THIS PLAN LIES WITHIN THE METRO VANCOUVER REGIONAL DISTRICT
CITY OF DELTA

FILE: 30966-2ST1
DATE: 2025/06/05
MAP: G-9(S)

SERVER:\JOBS\30966-2\DWG\LEGAL\30966-2ST1 M250 DATA\MS\30966-2.dwg JK

FLOORS PLAN OF STRATA LOTS 1, 2, AND 3

STRATA PLAN EPS11657 FOR REVIEW PURPOSES ONLY



THE INTENDED PLOT SIZE OF THIS PLAN IS
432mm IN HEIGHT BY 280mm IN WIDTH
WHEN PLOTTED AT A SCALE OF 1:250 (B SIZE)

GROUND FLOOR

SECOND FLOOR

THIRD FLOOR

LEGEND:

- S.L. DENOTES STRATA LOT
- (E) DENOTES ELECTRICAL
- (C) DENOTES COMMON PROPERTY - COMMON PROPERTY
- LCP DENOTES LIMITED COMMON PROPERTY (TYPICAL)

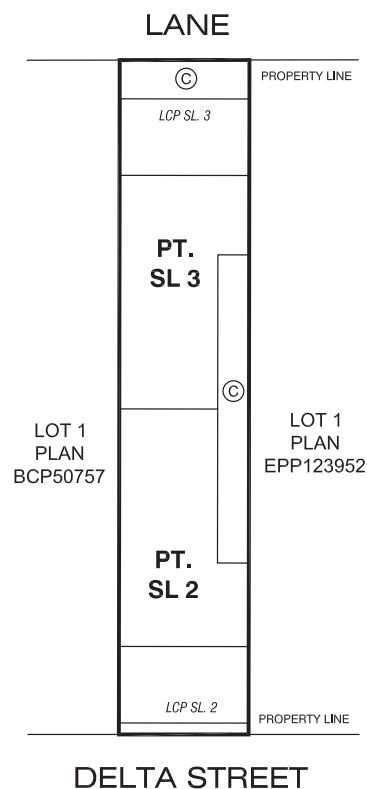
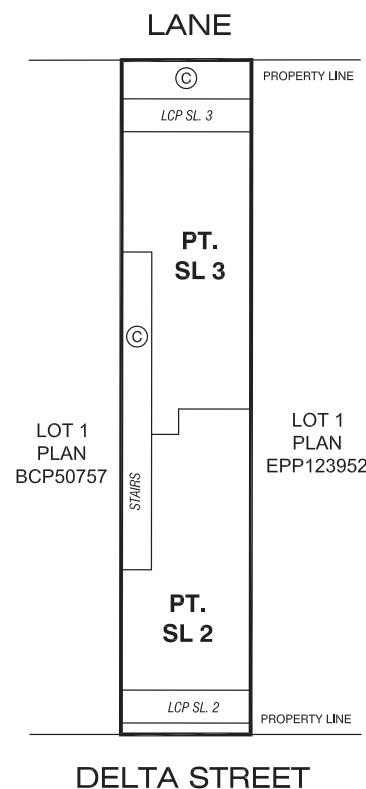
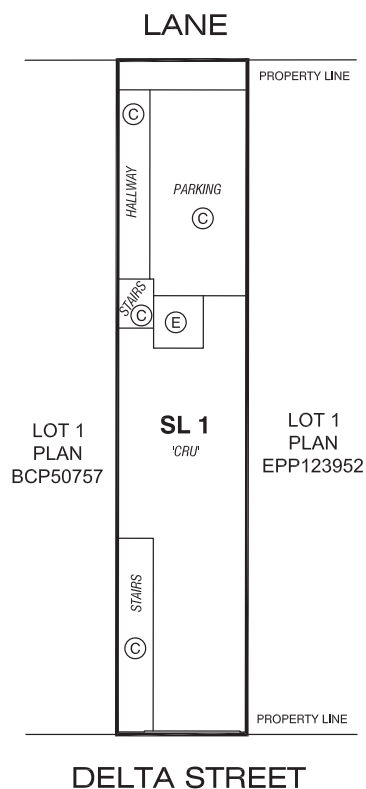
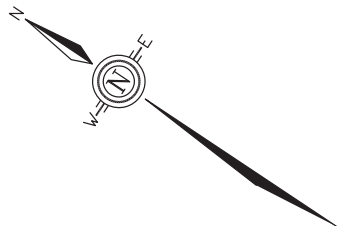

PRELIMINARY

CONNOR R. EMBLETON, BCLS (982)
THE XX DAY OF XXXX, 2025

WATSON & BARNARD
B.C. LAND SURVEYORS
1524 56th STREET
DELTA, B.C., V4L 2A8
P: 604 943 9433

THIS PLAN LIES WITHIN THE METRO VANCOUVER REGIONAL DISTRICT
CITY OF DELTA

FILE: 30966-2ST1
DATE: 2025/06/05
MAP: G-9(S)

SERVER:\OBS\30966-2\DWG\LEGAL\30966-2ST1_M250_DATA\MS\30966-2.dwg JK